

aquatica®

Function, Form & Fashion



Purescape™ 118R
Corner Acrylic Bathtub

Installation & Care Manual

EU & International

Purescape™ 118R

Corner Acrylic Bathtub

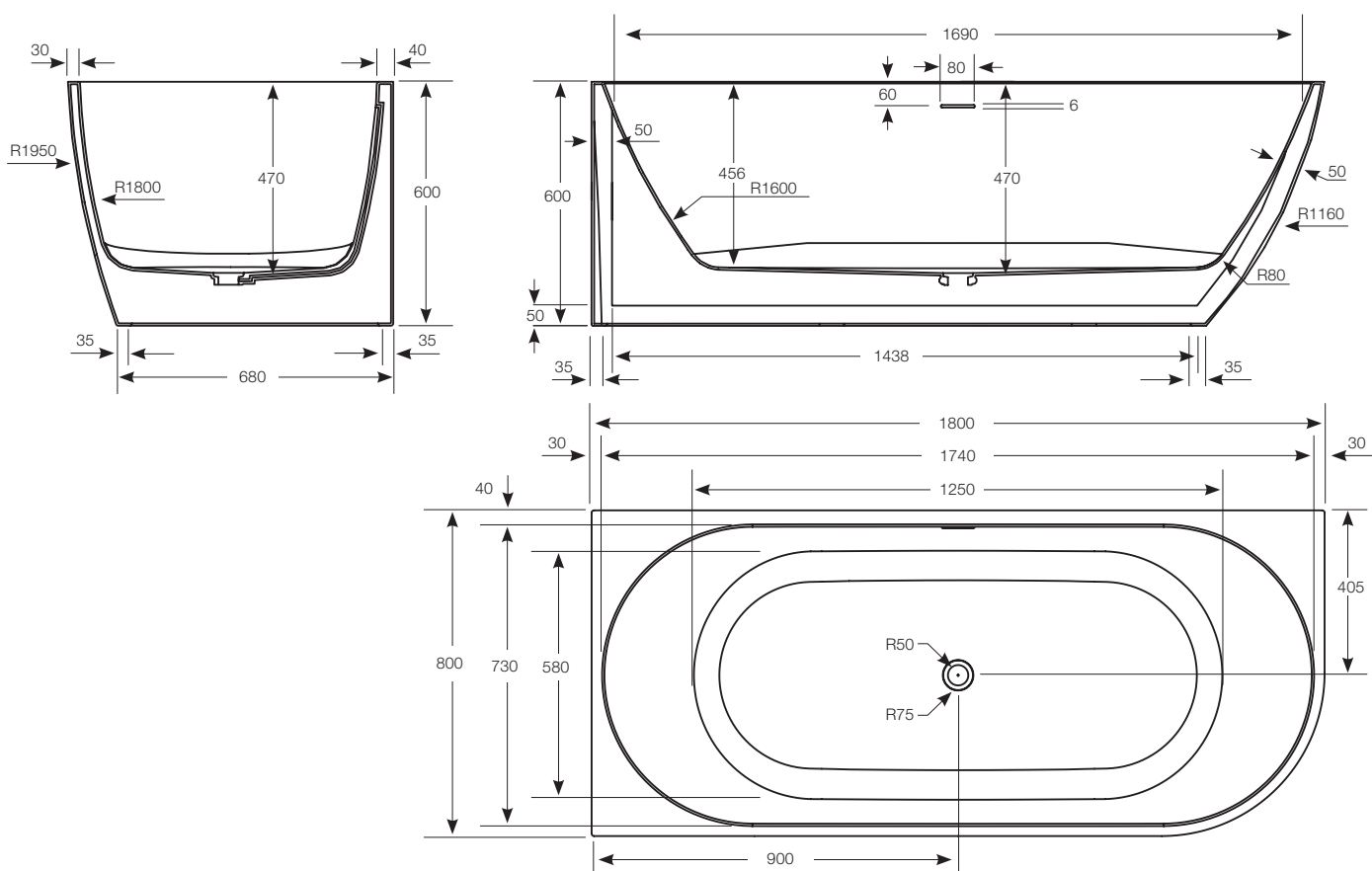
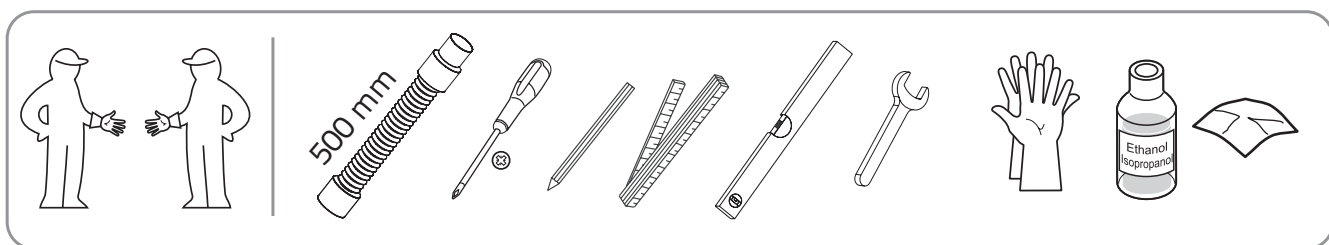
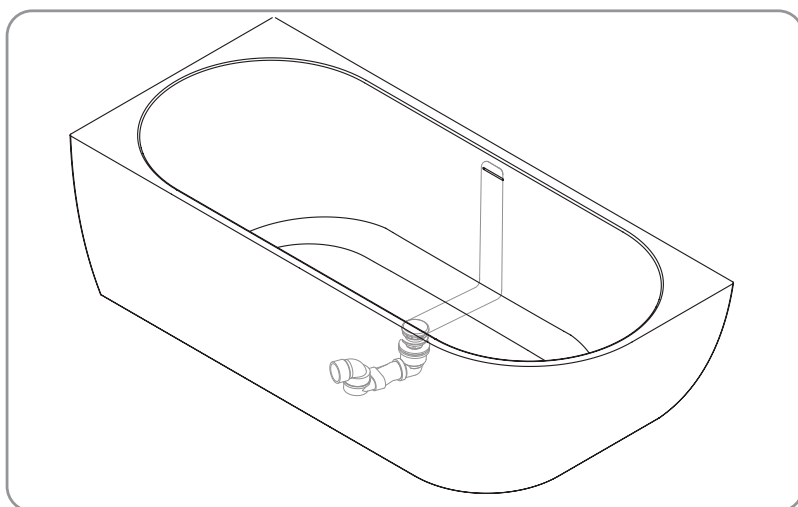



EUROPE INSTALL PROCEDURE

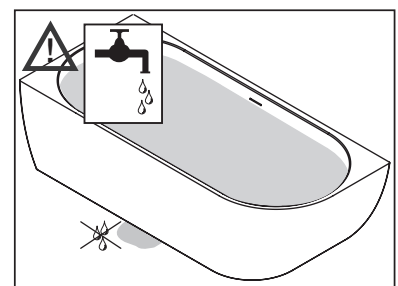
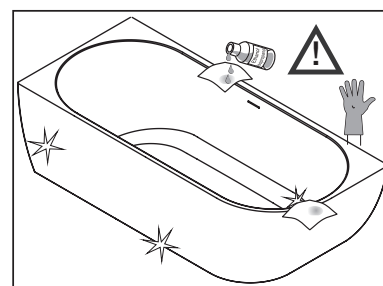
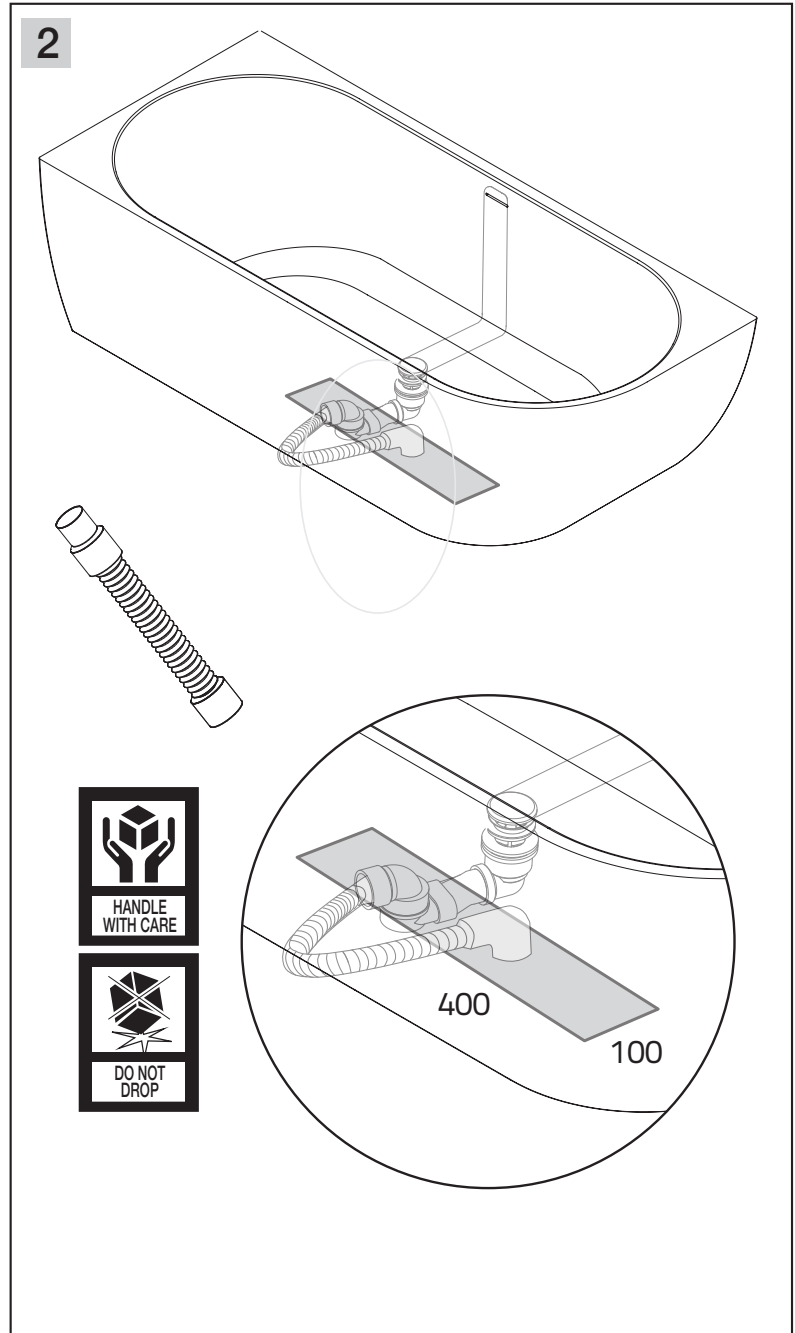
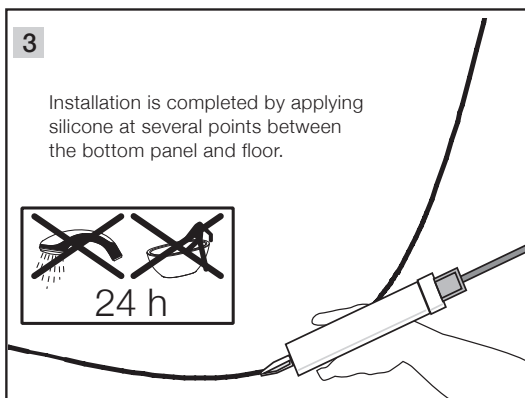
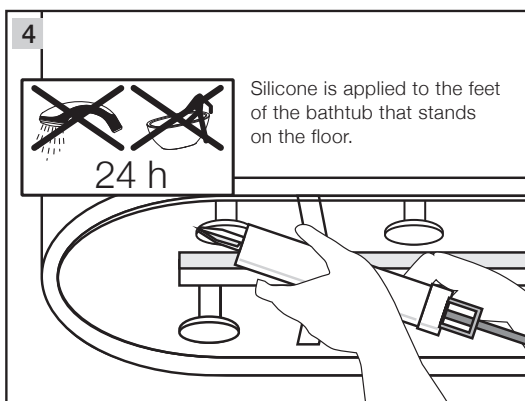
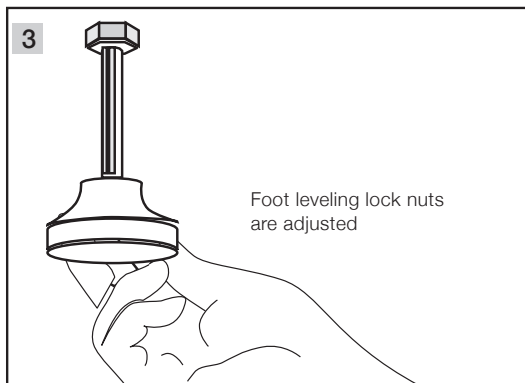
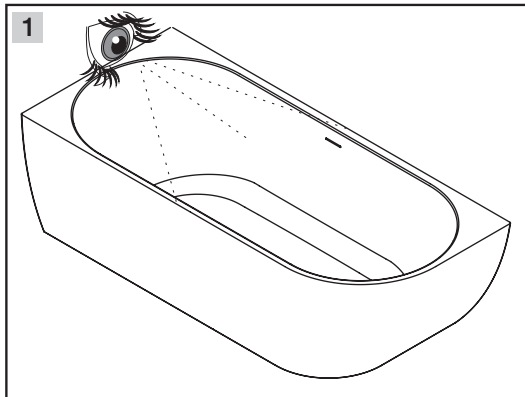

Purescape™ 118R - Maintenance Instructions

Purescape™ 118R - Инструкция по уходу

Purescape™ 118R - Installation & Entretien

Purescape™ 118R - Manuale per il corretto mantenimento

Purescape™ 118R - Instrucciones para la correcta manutención

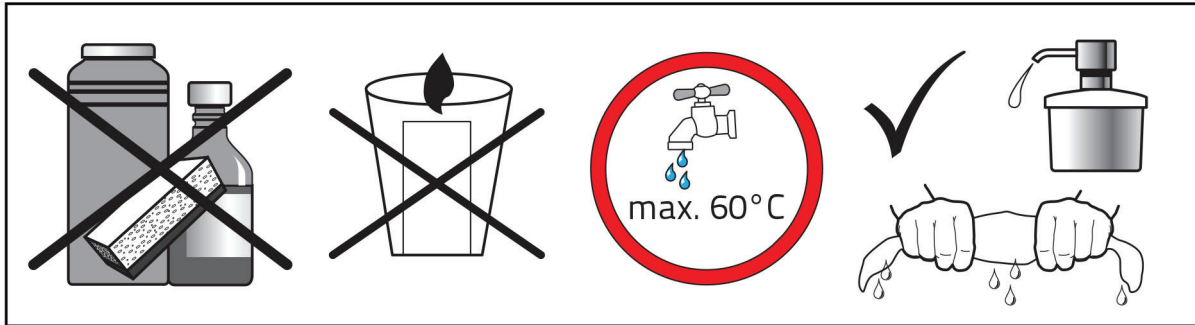

Maintenance Instructions

The smooth surface of your Aquatica® Acrylic Bathtub accumulates hardly any dirt, and can be maintained by simply cleaning with a soft cloth, using a mild detergent in water, then wiping over with a dry cloth.

Avoid using abrasive cleansers or solvents, which will cause damage to the surface. Damage caused by use of these products, or any other inappropriate treatment, is not covered by our guarantee.



Инструкция по уходу

Поверхность легко чистится. За счет гладкости грязь к ней не прилипает. Для регулярного ухода используйте мягкую ткань, мыльный раствор и воду. После чистки вытирайте поверхность сухой тканью, которая хорошо впитывает влагу.

Не используйте губки с абразивной поверхностью и агрессивные растворители, которые могут повредить ванну. Повреждения, возникшие вследствие неправильного ухода, не покрываются гарантией.



Installation & Entretien

Cette surface est facile à entretenir et à nettoyer. Sa surface particulièrement lisse, ne retiens que très peu la saleté. Un entretien quotidien nécessite simplement l'utilisation d'un chiffon doux, de l'eau et un peu de savon. Essuyer avec un chiffon sec. L'utilisation de détergents ou de solvants endommageraient cette surface. Les dommages resultants d'un traitement non conforme effectué par l'utilisateur sont exclus de la garantie que nous offrons.



Manuale per il corretto mantenimento

La superficie necessita di pulizia ed accorgimenti per il corretto mantenimento. Una superficie liscia non accumula lo sporco. Usare una spugnetta con del detergente non aggressivo per una pulizia regolare. Asciugare con un panno. Evitare l'uso di solventi o materiali abrasivi: potrebbero rovinare la superficie.

Un danno causato da trattamento inappropriato non verrà coperto dalla garanzia.



Instrucciones para la correcta manutención

La superficie debe de ser limpiada y adecuadamente mantenida. Una superficie lisa no acumula suciedad.

Utilice una esponja con un detergente suave para la limpieza diaria. Seque con un paño.

No utilice disolventes o materiales abrasivos ya que podrían dañar la superficie.

Los daños causados por el tratamiento inadecuado no serán cubiertos por la garantía.

CE

AQUATICA PLUMBING EUROPE LTD
VAT: LV40103634778
"Dienvidi" Industrial Park
Daugmales pagasts,
Kekavas novads LV-2124
Latvia

Conforms to: BS EN 14516:2015+A1:2018,
ASME A112.19.7-17/CSA B45.10-17